

MOBILE THERMAL PRINTER

User Manual

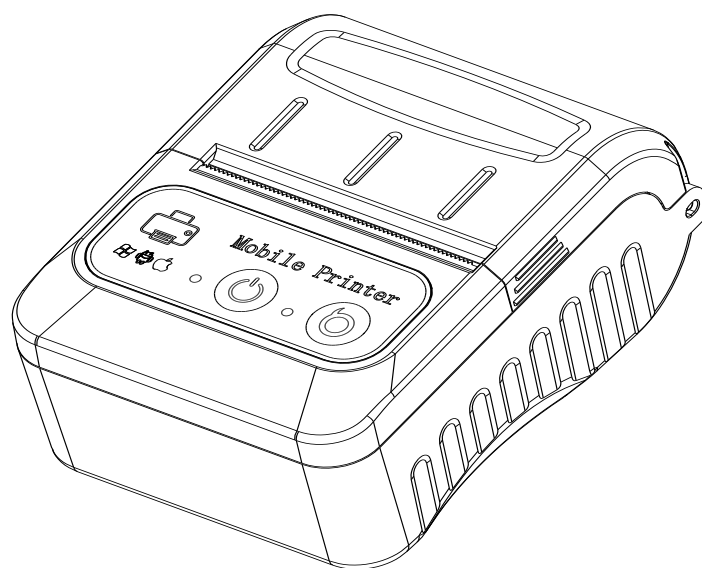

PRECAUTIONS

1. Safety Precautions

- 1) Be sure to use the specified battery and power supply provided by our company.
- 2) Connection to an improper power supply may cause burning, explosion or damage to printer.
- 3) Don't put the battery into fire or water, don't disassemble or modify the battery, don't be short circuit, otherwise may result in injury or even fire explosion.
- 4) If the printer would not be used for a long time, be sure to take off the battery, otherwise the battery may leak liquid which is corrosive. If improper operation causes battery leak, and the liquid is spattered on the skin or clothes, please wash it with water. if spattered into eyes, please rinse them with water thoroughly and soon see a doctor.
- 5) Please do not open the paper case cover while it is printing or just when printing is over, do not touch the print head with hand or body, overheat may cause scald.

2. Operation Precautions

- 1) Water or other liquid should not spill into the printer, also the printer should not be exposed in rain or else may cause printer damage.
- 2) Please do not open the paper case cover when it is printing, otherwise the printer may work improperly.
- 3) When printing with Bluetooth interface, the communication distance should be within 10 meters, otherwise the printer doesn't print or it will print rubbish codes.
- 4) Too high (50°C) or too low (-5°C) temperature and too high (80%) or too low (25%) relative humidity both will affect the printing quality.
- 5) The thermal paper in poor quality or stored for too long time also may reduce the printing quality or even damage the printer.

3. Storage Precautions

- 1) The printer should be placed in such an environment that the temperature is between -20°C to 70°C, and the relative humidity is within 5% to 95%.
- 2) If the printer will be stored for a long time, please be sure to take out the battery, otherwise may damage the battery and printer.
- 3) Normal thermal paper can't be kept too long, if you need to keep the receipt for a long period, please choose long term effective thermal paper.
- 4) The thermal paper should be keep away from high temperature environment and point-blank sunshine.

4. Battery Safety Precautions

Be sure to carefully read the user manual before using this product. Ignore the following instructions may cause battery overheating, burning, explosion, damages the performance and reduce the product life.

- ① Do not allow water, sea water from entering or leaking into the battery inside. If the battery internal safety device burn, when charging it, it may produce abnormal current, voltage, and chemical reaction to cause the battery overheating, burning and explosion.
- ② Do not use or place the battery nearby the stove or other high temperature places. Excessive heat may damage the resin shell or the insulation materials, thereby cause short-circuit inside the battery and result the battery overheating, burning and explosion.
- ③ When charging, use a specified charger. Other conditions (high temperature, high pressure/high current, using the modified battery charger, etc.) excluded here may result in over-charging the battery and abnormal current or voltage, cause abnormal chemical reaction, and may cause the battery overheating, burning or explosion.
- ④ Do not make the battery contact with the power outlet or car cigarette lighter socket. This may cause high pressure and excessive current, and lead the battery overheating, burning or explosion.
- ⑤ Do not heat the battery or put the battery into fire. This may melt insulation material and damage safety devices or safety equipment, then ignite electrolytic solution, and cause the battery overheating, burning or explosion.
- ⑥ Do not use the battery with contrary (+) and (-) location. In the charging process, this will cause the reverse charging and may cause abnormal chemical reaction. During use, may appear unpredictable current exception, and cause the battery overheating, burning or explosion.
- ⑦ Battery clearly marks with positive and negative. When connect the battery with the charger or printer, be sure to verify the correct battery orientation. Reverse insertion will cause the reverse charging and may cause abnormal chemical reaction, and then may cause the battery overheating, burning or explosion.
- ⑧ Do not make the battery (+) and (-) connect with any metal. Also, do not carry along or store batteries with metal objects, such as necklaces, hair clips and so on. Battery internal short circuit may cause excessive current, and lead to the battery overheating, burning or explosion and the adjacent metal objects (necklaces, hairpins, etc.) may be overheated.
- ⑨ Do not throw or heavily attack the battery. If internal safety device of the batteries burned, the battery charging may cause abnormal current and voltage, and abnormal chemical reaction, and lead the battery overheating, burning or explosion

CHAPTER 1 BRIEF INTRODUCTION

1.1 Appearance

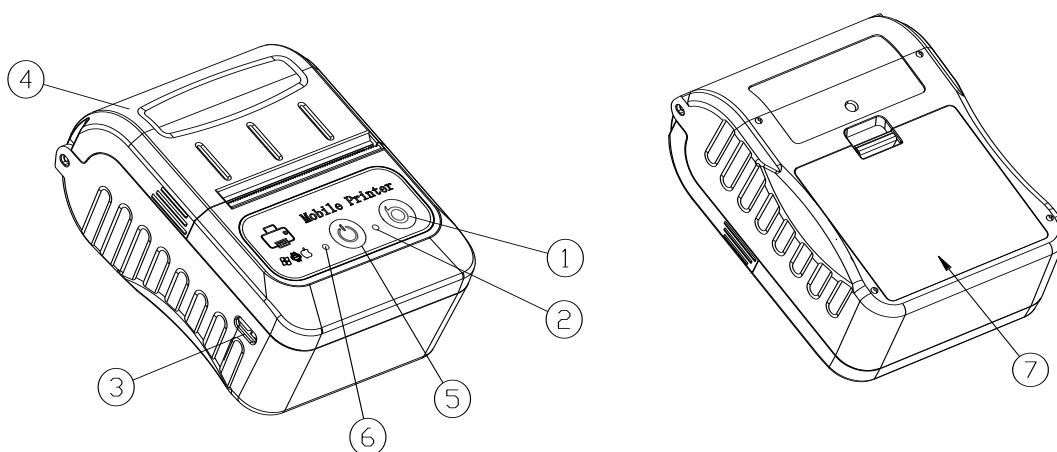

- | | |
|-------------------|---|
| 1. Feed button | 2. Status indicator (Blue LED+ Green LED) |
| 3. USB interface | 4. Printer top cover |
| 5. Power button | 6. Power indicator (Red LED+ Blue LED) |
| 7. Li-ion battery | 8. Belt buckle |

1.2 Accessories

Li-ion Battery Power Plug /[5V/1A] USB cable(type C) Paper Roller User manual

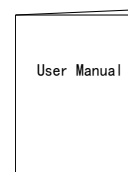
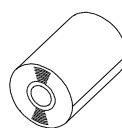
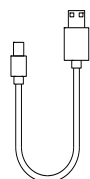
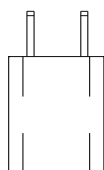
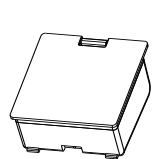

CHAPTER 2 SPECIFICATIONS

ITEMS		PARAMETERS
Printing	Method	Thermal dot line printing
	Resolution	203dpi, 8dots/mm
	Speed (Max)	70mm/s
Paper	Width	58mm
	Valid printing width	48mm
	Thickness	60~80μm
	Roller diameter	≤40mm
	Loading	Easy loading mechanism
Interface		Bluetooth and USB
Character Set	Font	ASCII:9×17,12×24, Multiple code pages support
Barcode Symbologies	1D	UPC-A, UPC-E, EAN8, EAN13, CODE39, ITF, CODEBAR, CODE128, CODE93
	2D	QR code
Graphics		Support bitmap printing with different density and user defined bitmap printing (Max. 40K for per bitmap, and Max. 64K for total)
Detection	Sensors	Paper out/ low battery
LED indicator		Power (red)
		Bluetooth (blue)
		Charging (Green)
		Error/Paper out (blue)
Charging	Charger	5V/1A in adapter
	Battery	1500mAh/7.4V rechargeable Li-ion battery. Full charge can print 350~300m (printing density not more than 12.5%) or 250~300mm (printing density not more than 25%)
Physical characteristics	Working condition	-5°C ~ 50°C, 25% ~ 80% R.H, no-condensation
	Storage condition	-40°C ~ 60°C, 5% ~ 95% R.H, no-condensation
	Dimension	103.7*76.8*45.8mm
	Weight	230g (without paper roll)
Software	SDK	Android and iOS
	Driver	Win7/Win8/Win10

CHAPTER 3 OPERATION METHODS

3.1 Preparation Before Using

3.1.1 Li-ion Battery Installation

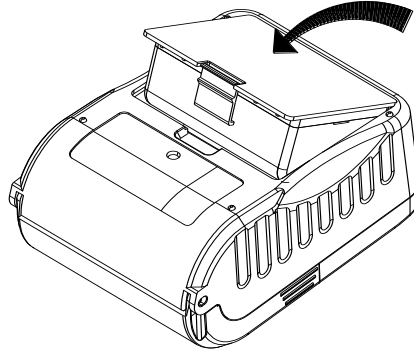

- 1) Refer to the above picture, put the battery in the battery slot (pay attention to the correct positive and negative).
- 2) Close the battery case.

3.1.2 Paper Loading

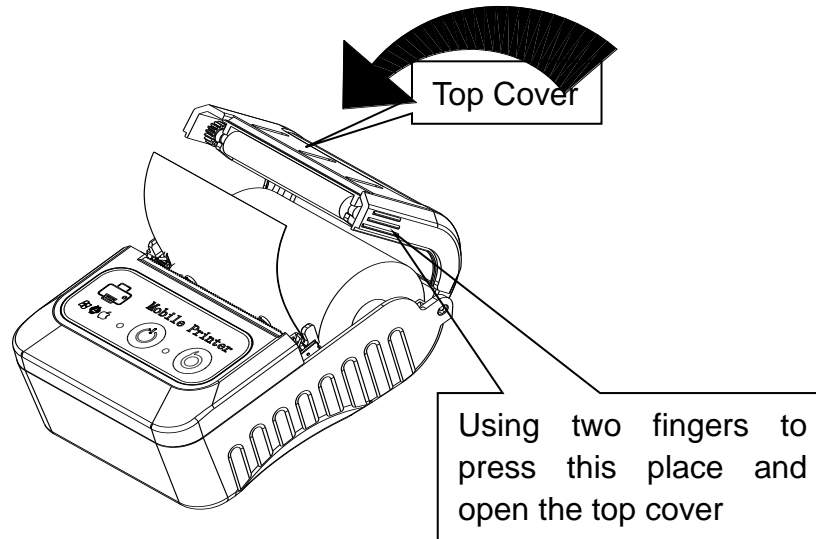

- 1) Using two fingers to press this place and open the top cover (see above picture).
- 2) Put into paper roller (pay attention to the paper direction, If loaded reversely, it won't print.) and close the top cover (Pull paper little out of paper case).

3.2 Basic Functions

3.2.1 Power On

The printer is power on by pressing the **【POWER】** button lasting for about 2 seconds, and the power indicator is bright in red color.

Notice: when the battery is almost exhausted, the status indicator blinks in blue color. In this case, you must charge the battery.

3.2.2 Power Off

The printer is power off after holding down the **【POWER】** button for about 2 seconds. All the indicators are off when the printer is off

3.2.3 Self-test

The self-test indicates the printer's current settings, status and whether the printer has any problem. Hold down the **【FEED】** button while press **【POWER】** button about 2 seconds, the self-test begins. The printer is ready to receive data as soon as it completed self-test.

3.2.4 Paper Feeding (Manual paper feeding)

Users could use **【FEED】** button to feed paper manually when printer on normal working status. When the printer feed paper for 250mm and there is black mark on paper be recognized, the printer will stop feeding paper.

3.2.5 Battery Charging

Before the battery runs out of power, the printer will alarm and the blue LED indicator will flash slowly. It will power off automatically when continues printing.

Charging Method:

- ① Connect the power charger to the power connector of the printer.
 - ② Plug the power charger into an electrical outlet (Printer could be in use when charging).
- Power-off/Power-on charging: LED light will always indicate green color and goes off when fully charged.

NOTE: Please use the original battery and power charger, otherwise printer may be damaged or even cause explosion.

3.3 Printer connecting and Printing

3.3.1 Bluetooth pairing and printing

PDA with Bluetooth interface, laptop and other information terminals can drive the mobile thermal printer MPT-II. Instructions as follows:

1. Power on printer.
2. Primary device search for outer Bluetooth devices.
3. If there are some outer Bluetooth devices, choose MPT-II.
4. Enter password "0000".
5. Finish matching.

Note: when pairing, mobile thermal printer MPT-II must be on. Do not set many printers on when pairing, otherwise it can't figure out which printer is the one that succeed in pairing. Usually, one printer pair with one host machine, it is possible that one printer pair with more host machines too.

3.4 LED Indicator and Buzzer Definition

There are one buzzer and four LED indicators to indicate the printer status. LED indicators indicate current status and buzzer indicates the changes of printer status. The four LED indicators are MODE_RED, MODE_BLUE, FEED_BLUE, FEED_GREE.

- 1) MODE_RED (up left): Power on indicator, lighting after printer power on,
- 2) MODE_BLUE (down left): Bluetooth indicator, lighting after BT connected. It is because the MODE_RED is on, so the MODE on left side will be in orange,
- 3) FEED_BLUE (up right): Paper out indicator, it is on when there is out of paper,
- 4) FEED_GREEN (down right): Power charging indicator, it is blinking when printer is power on and under charging, lighting if power off and under charging.

Printer State	BT State	BT LED (Blue)	Power LED/ (Red)	ERROR LED (Blue)	CHARGE LED (Green)	Buzzer	Note
Power On			ON			Once	
Standby	OFF		ON				
	ON	ON					
Charging	OFF		ON		ON	Once	Green light off when full charged
	ON	ON					
Paper Out	OFF		ON	ON		ON	Blue light blink when charging and on when full charged
	ON	ON				ON	
Low Voltage	OFF		ON			ON	When start to charging, buzzer off
	ON	ON					
High Temperature	OFF		ON	Blink			
	ON	ON					
Firmware Upgrade		ON	ON	ON			
Standby			Blink				No standby when BT connected or paper out
Power Off					ON [when charging]	Twice	Green light off when full charged
Note:	When BT blue light and power red light both on, there appear purple color.						

Note:

- 1) **【Power LED】**: when turn on the printer, the **Power LED** will be on.
- 2) **【BT LED】**: when the printer is connected by smart phone or other master device which is with Bluetooth, **BT LED** will be on.
- 3) **【ERROR LED】**: Once error was found in the printer, the **ERROR LED** will flash.
- 4) **【CHARGE LED】**: when printer is in charging, the **CHARGE LED** will be on.